

Turmdrehkran

Tower Crane / Grue à tour / Gru a torre / Grúa torre
Guindaste de torre / Башенный поворотный кран

280 HC-L 12/24 Litronic®

280 HC-L 8/16

280 HC-L 12/24

280 HC-L 16/28

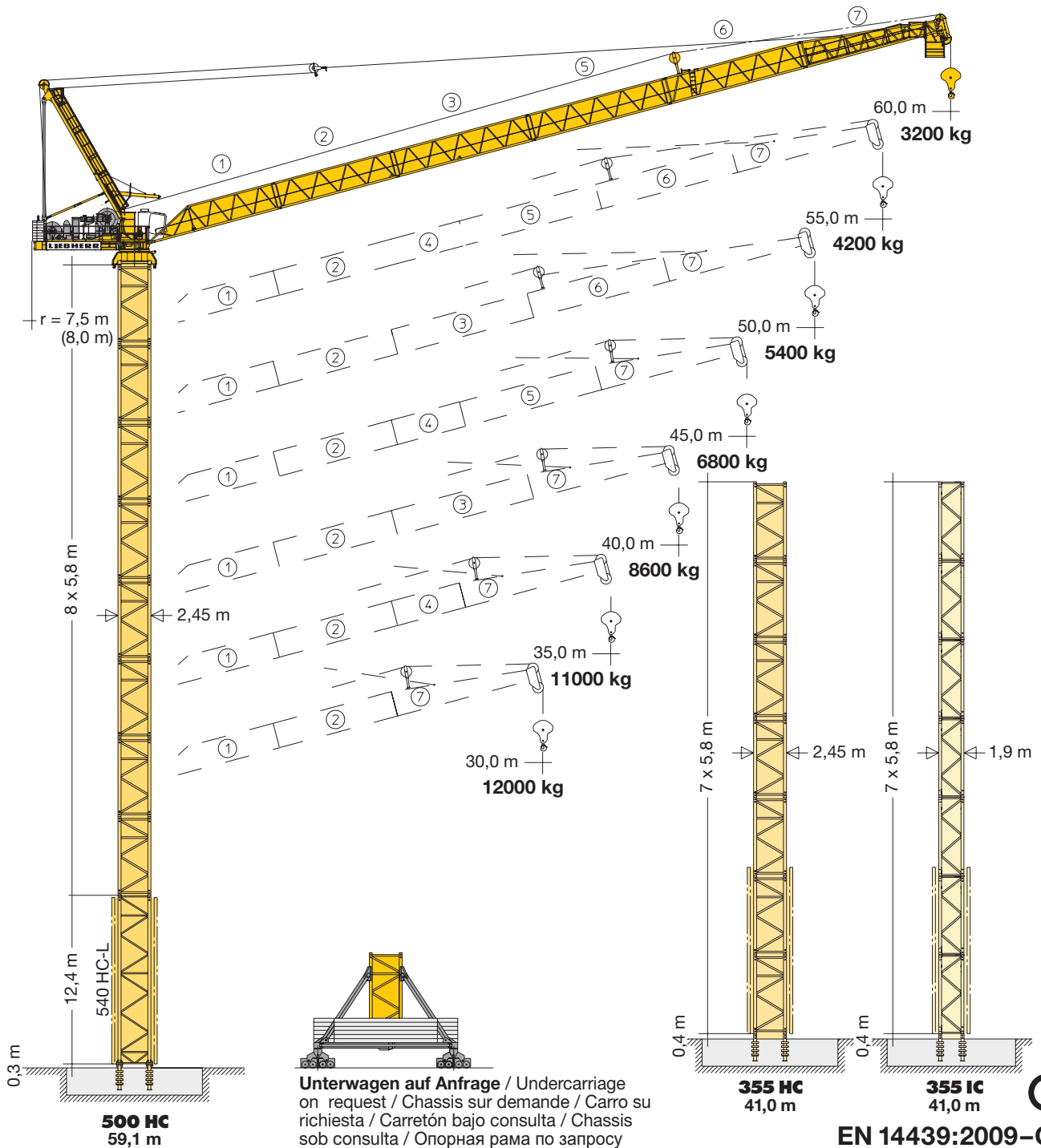

Unterwagen auf Anfrage / Undercarriage
on request / Chassis sur demande / Carro su
richiesta / Carretón bajo consulta / Chassis
sob consulta / Опорная рама по запросу

LIEBHERR

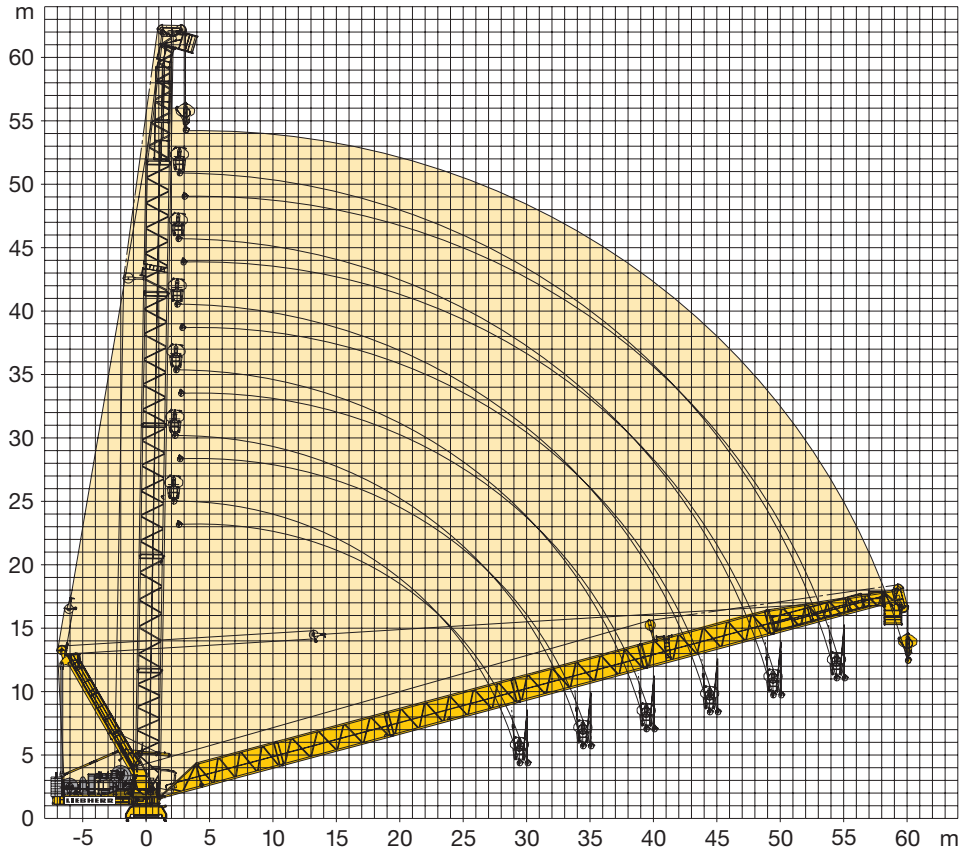

Turmhöhen

Tower heights / Hauteur de mât / Altezze torre / Alturas de torre / Alturas de torre / Высота башни



| C 25 | 355 HC | | 500 HC | | | 500 HC | | | | 355 IC | | | | | | | |
|------|------------------------------------------------------------|--------|--------|--------|--------|--------|--------|--------|--------|--------|--------|--------|--------|--------|--------|--------|--------|
| | Ausleger / Jib / Flèche / Braccio / Pluma / Lança / Стрела | | | | | | | | | | | | | | | | |
| | 30,0 m | 45,0 m | 30,0 m | 30,0 m | 45,0 m | 55,0 m | 30,0 m | 35,0 m | 45,0 m | 50,0 m | 60,0 m | 30,0 m | 35,0 m | 40,0 m | 45,0 m | 55,0 m | 60,0 m |
| 11 | - | - | 64,2* | - | - | - | 76,5* | - | - | - | - | - | - | - | - | - | - |
| 10 | - | - | 58,4 | 58,4* | - | - | 70,7 | 70,7* | - | - | - | - | - | - | - | - | - |
| 9 | - | - | 52,6 | 52,6 | 52,6* | - | 64,9 | 64,9 | 64,9* | - | - | 52,6* | - | - | - | - | - |
| 8 | 46,8* | - | 46,8 | 46,8 | 46,8 | - | 59,1 | 59,1 | 59,1 | 59,1* | - | 46,8 | 46,8* | - | - | - | - |
| 7 | 41,0 | 41,0* | 41,0 | 41,0 | 41,0 | - | 53,3 | 53,3 | 53,3 | 53,3 | - | 41,0 | 41,0 | 41,0* | - | - | - |
| 6 | 35,2 | 35,2 | 35,2 | 35,2 | 35,2 | - | 47,5 | 47,5 | 47,5 | 47,5 | - | 35,2 | 35,2 | 35,2 | 35,2 | - | - |
| 5 | 29,4 | 29,4 | 29,4 | 29,4 | 29,4 | - | 41,7 | 41,7 | 41,7 | 41,7 | - | 29,4 | 29,4 | 29,4 | 29,4 | - | - |
| 4 | 23,6 | 23,6 | 23,6 | 23,6 | 23,6 | - | 35,9 | 35,9 | 35,9 | 35,9 | - | 23,6 | 23,6 | 23,6 | 23,6 | - | - |
| 3 | 17,8 | 17,8 | 17,8 | 17,8 | 17,8 | - | 30,1 | 30,1 | 30,1 | 30,1 | - | 17,8 | 17,8 | 17,8 | 17,8 | - | - |
| 2 | 12,0 | 12,0 | 12,0 | 12,0 | 12,0 | - | 24,3 | 24,3 | 24,3 | 24,3 | - | 12,0 | 12,0 | 12,0 | 12,0 | - | - |
| 1 | 6,2 | 6,2 | 6,2 | 6,2 | 6,2 | - | 18,5 | 18,5 | 18,5 | 18,5 | - | 6,2 | 6,2 | 6,2 | 6,2 | - | - |
| 0 | 0,4 | 0,4 | 0,4 | 0,4 | 0,4 | - | 12,7 | 12,7 | 12,7 | 12,7 | - | 0,4 | 0,4 | 0,4 | 0,4 | - | - |
| | m | | m | | | m | | | | m | | | | | | | |
| | | | | | | | | | | | | | | | | | |

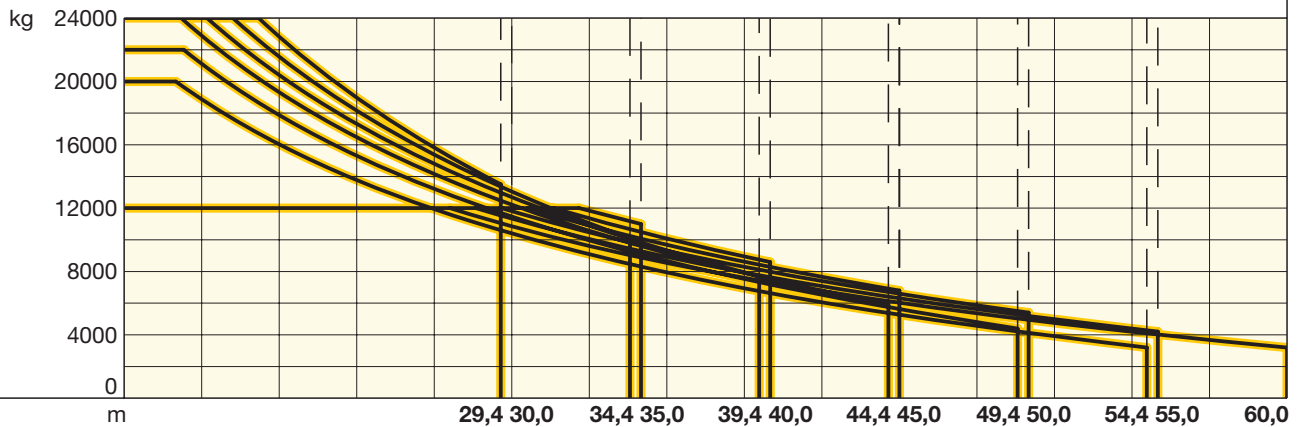

* Außer Betrieb, Auslegerstellung 15° – 70°. / Out of operation, jib position 15° – 70°. / Hors service, position de flèche 15° – 70°. / Fuori servizio, posizione braccio 15° – 70°. / Posición de pluma, fuera de servicio 15° – 70°. / Posição da lança, fora de serviço 15° – 70°. / Вне работы, положение стрелы под углом 15° – 70°.

| m | m/kg | m/kg | | | | | | | | | | |
|------|---------------------|-------|-------|-------|-------|-----------------|-----------------|----------------|----------------|----------------|----------------|------|
| | | 18,0 | 21,0 | 24,0 | 27,0 | 30,0 | 35,0 | 40,0 | 45,0 | 50,0 | 55,0 | 60,0 |
| 60,0 | 4,0 – 27,6 12000 | 12000 | 12000 | 12000 | 12000 | 10860 | 8880 | 7320 | 6030 | 4950 | 4020 | 3200 |
| 55,0 | 4,0 – 28,6 12000 | 12000 | 12000 | 12000 | 12000 | 11330 | 9280 | 7650 | 6310 | 5180 | 4200 | |
| | 4,0 – 17,0 20000 | 18870 | 16030 | 13770 | 11930 | 10400 | 8310 | 6640 | 5270 | 4110 | 54,4 m 3200 | |
| 50,0 | 4,0 – 29,6 12000 | 12000 | 12000 | 12000 | 12000 | 11810 | 9680 | 7980 | 6590 | 5400 | | |
| | 4,0 – 17,3 22000 | 21110 | 17870 | 15310 | 13210 | 11460 | 9080 | 7180 | 5620 | 49,4 m 4400 | | |
| 45,0 | 4,0 – 30,6 12000 | 12000 | 12000 | 12000 | 12000 | 12000 | 10070 | 8290 | 6800 | | | |
| | 4,0 – 17,2 24000 | 22800 | 19300 | 16470 | 14160 | 12230 | 9600 | 7500 | 44,4 m 5900 | | | |
| 40,0 | 4,0 – 31,6 12000 | 12000 | 12000 | 12000 | 12000 | 12000 | 10480 | 8600 | | | | |
| | 4,0 – 18,2 24000 | 24000 | 20400 | 17320 | 14800 | 12690 | 9830 | 39,4 m 7700 | | | | |
| 35,0 | 4,0 – 32,6 12000 | 12000 | 12000 | 12000 | 12000 | 12000 | 11000 | | | | | |
| | 4,0 – 19,2 24000 | 24000 | 21560 | 18160 | 15380 | 13050 | 34,4 m 10100 | | | | | |
| 30,0 | 4,0 – 30,0 12000 | 12000 | 12000 | 12000 | 12000 | 12000 | | | | | | |
| | 4,0 – 20,2 24000 | 24000 | 22820 | 18970 | 15820 | 29,4 m 13500 | | | | | | |

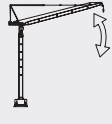



Tragfähigkeiten gültig bis 100 m Hubhöhe. Über 100 m Hubhöhe reduziert sich die Tragfähigkeit um das zusätzliche Seilgewicht. / Lifting capacities valid up to 100 m hoisting height. Over 100 m hoisting height, the lifting capacity is reduced by the additional rope weight. / Capacités de levage valables jusqu'à 100 m de hauteur sous crochet. Au-dessus de 100 m de hauteur sous crochet, la capacité de levage est réduite du poids de câble supplémentaire. / Portate valide fino a 100 d'altezza di sollevamento. Oltre i 100 m si riduce la portata causa il peso addizionale della fune. / Cargas válidas hasta altura de 100 m. Por encima de los 100 m se reduce la carga por el peso adicional del cable. / Cargas válidas ate à altura de 100 m. Para alem dos 100 m, reduz-se a carga pelo peso adicional do cabo. / Грузоподъемность действительна до 100 м высоты подъема. Свыше 100 м высоты подъема грузоподъемность сокращается на вес дополнительного каната.

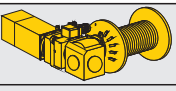

| | | |
|-----------------------------------------------------------------------------------|-------------------------------------------------------------------------------------------------------------------------------------------------------------------------------|-----------------------------------|
|  | U/min 0 ↔ 0,7 sl./min tr./min | 2 x 7,5 kW FU |
|  | 2,8 min 2,2 min 1,8 min | 45 kW FU 65 kW FU 110 kW FU |
|  | Unterwagen auf Anfrage / Undercarriage on request / Chassis sur demande / Carro su richiesta / Carretón bajo consulta / Chassis sob consulta / Опорная рама по запросу | |

| | | | |
|-------------------------------------------------------------------------------------|----------|-----------|-----------|
|  | 65 kW FU | 110 kW FU | 110 kW FU |
|  | 65 kW FU | 65 kW FU | 110 kW FU |
| kVA | 143,0 | 185,0 | 226,0 |

kVA reduzierbar bei zu geringer Netz-Anschlussleistung, siehe BAL.
 kVA can be reduced in case of too little power of the mains, see instruction manual. / kVA peut être réduit en cas de trop faible puissance du réseau, voir manuel d'instruction. / kVA riducibili in caso di potenza di rete ridotta (si veda manuale uso e manutenzione) / kVA variable para potencia de red demasiado pequeña, ver Manual de instrucciones. kVA reduzível no caso de capacidade da rede elétrica muito baixa, ver manual de instruções. / Количество кВА может быть сокращено до минимальной общей потребляемой мощности, см. инструкцию по эксплуатации.

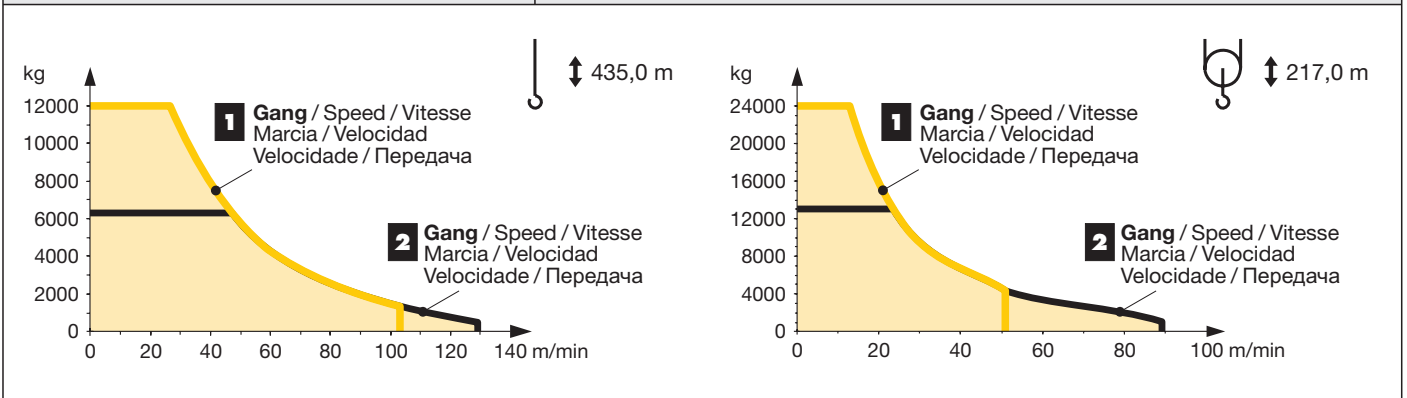
| | | | | | | | |
|-----------------------------------------------------------------------------------|-----------------------------------------------------------------------------------|-------------------------------------------------------------------------------------------------------------------|---------------|-------------------|----------|---------------|------------------|
|  |  | ↔ stufenlos / stepless / régl. continu / régl. progressive / sin escalones sem degraus / бесступенчатый | | | | | |
| 65 kW FU WIW 280 VZ 411 | max. 1290 m | kg | m/min | kg | m/min | | |
|  | 4 Lagen / Layers Couches / Avvolgimenti Camadas / Capas / Слоёв | 1 | 12000 1300 | 0 ↔ 27 0 ↔ 103 | 1 | 24000 4300 | 0 ↔ 13 0 ↔ 51 |
| | | 2 | 6300 500 | 0 ↔ 47 0 ↔ 129 | 2 | 13000 1100 | 0 ↔ 23 0 ↔ 89 |

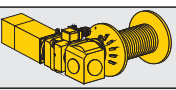

| | | | | | | | |
|-------------------------------------------------------------------------------------|-------------------------------------------------------------------------------------|-------------------------------------------------------------------------------------------------------------------|---------------|--------------------|----------|----------------|-------------------|
|  |  | ↔ stufenlos / stepless / régl. continu / régl. progressive / sin escalones sem degraus / бесступенчатый | | | | | |
| 110 kW FU WIW 300 VZ 412 | max. 1290 m | kg | m/min | kg | m/min | | |
|  | 4 Lagen / Layers Couches / Avvolgimenti Camadas / Capas / Слоёв | 1 | 12000 5300 | 0 ↔ 45 0 ↔ 83 | 1 | 24000 11200 | 0 ↔ 23 0 ↔ 42 |
| | | 2 | 6300 2100 | 0 ↔ 78 0 ↔ 144 | 2 | 13200 5600 | 0 ↔ 39 0 ↔ 72 |
| | | 3 | 3000 300 | 0 ↔ 131 0 ↔ 240 | 3 | 7100 2300 | 0 ↔ 65 0 ↔ 120 |

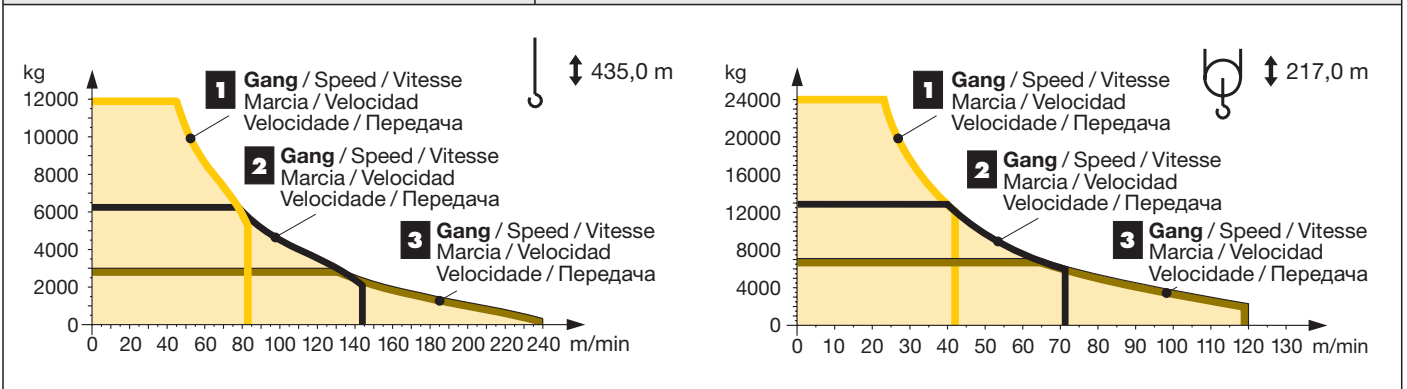









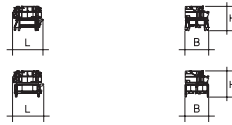



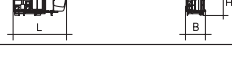





| | | 355 IC | | | | | |
|-------------------------------------------|--|------------------------------------------------------------|-----------------------------|---------------|--------|-----------------------------|---------------|
| | | Ausleger / Jib / Flèche / Braccio / Pluma / Lança / Стрела | | | | | |
| | | 30,0 m | 35,0 / 40,0 / 45,0 / 50,0 m | 55,0 / 60,0 m | 30,0 m | 35,0 / 40,0 / 45,0 / 50,0 m | 55,0 / 60,0 m |
| 8 7 6 5 4 3 2 1 0 | | 52,6 | – | – | 52,2 | – | – |
| | | 46,8 | 46,8 | – | 46,4 | 46,4 | – |
| | | 41,0 | 41,0 | 41,0 | 40,6 | 40,6 | 40,6 |
| | | 35,2 | 35,2 | 35,2 | 34,8 | 34,8 | 34,8 |
| | | 29,4 | 29,4 | 29,4 | 29,0 | 29,0 | 29,0 |
| | | 23,6 | 23,6 | 23,6 | 23,2 | 23,2 | 23,2 |
| | | 17,8 | 17,8 | 17,8 | 17,4 | 17,4 | 17,4 |
| | | 12,0 | 12,0 | 12,0 | 11,6 | 11,6 | 11,6 |
| | | 0,4 m | 6,2 | 6,2 | 6,2 | 5,8 | 5,8 |

| | | 500 HC | | | | | |
|------------------------------------------------------|--|------------------------------------------------------------|----------------------|---------------|---------------|----------------------|---------------|
| | | Ausleger / Jib / Flèche / Braccio / Pluma / Lança / Стрела | | | | | |
| | | 30,0 / 35,0 m | 40,0 / 45,0 / 50,0 m | 55,0 / 60,0 m | 30,0 / 35,0 m | 40,0 / 45,0 / 50,0 m | 55,0 / 60,0 m |
| 10 9 8 7 6 5 4 3 2 1 0 | | – | – | – | 69,6 | – | – |
| | | 64,2 | – | – | 63,8 | 63,8 | – |
| | | 58,4 | 58,4 | – | 58,0 | 58,0 | 58,0 |
| | | 52,6 | 52,6 | 52,6 | 52,2 | 52,2 | 52,2 |
| | | 46,8 | 46,8 | 46,8 | 46,4 | 46,4 | 46,4 |
| | | 41,0 | 41,0 | 41,0 | 40,6 | 40,6 | 40,6 |
| | | 35,2 | 35,2 | 35,2 | 34,8 | 34,8 | 34,8 |
| | | 29,4 | 29,4 | 29,4 | 29,0 | 29,0 | 29,0 |
| | | 23,6 | 23,6 | 23,6 | 23,2 | 23,2 | 23,2 |
| | | 17,8 | 17,8 | 17,8 | 17,4 | 17,4 | 17,4 |
| | | 12,0 | 12,0 | 12,0 | 11,6 | 11,6 | 11,6 |

Außer Betrieb, Auslegerstellung 15° – 70°. / Out of operation, jib position 15° – 70°. / Hors service, position de flèche 15° – 70°. / Fuori servizio, posizione braccio 15° – 70°. / Posición de pluma, fuera de servicio 15° – 70°. / Posição da lança, fora de serviço 15° – 70°. / Вне работы, положение стрелы под углом 15° – 70°.

¹⁾ **Min. Verankerungshöhe kann bei max. Turmhöhe bzw. bei Hakenhöhe > 100m abweichen.** / Min. anchoring height may deviate at max. tower height resp. hook height > 100 m. / La hauteur d'ancrage min. peut différer en cas de hauteur de mât max. resp. en cas de hauteur sous crochet > 100m. / In caso dell'altezza max torre/gancio, l'altezza min. di ancoraggio può differire di > 100m. / La altura mínima de arriostamiento puede variar con una altura máxima de torre, es decir para alturas bajo gancho > 100m. / Em uma torre, com uma altura do gancho > 100 m a altura mín. do ancoramento pode variar. / Мин. высота крепления к зданию может изменяться при макс. высоте башни или при высоте крюка более 100м.

| Kranoberteil | | Upper part of crane / Partie supérieure de grue / Parte superiore della gru Parte superior grúa / Parte superior do guindaste / Верхняя часть крана | | L (m) | B (m) | H (m) | kg* | |
|-----------------------------------|----------------------------------------|---------------------------------------------------------------------------------------------------------------------------------------------------------------------------------------------------------------------------------------------------------------------------------------------------------------------------------------------------------------------------------------------------------------------------------------------------------------------------------------------------------------------------------------------------|--------------------------------------------------------------------------------------|--------|-------|-------|------|--------|
| Pos. Item Rep Voce Pos. Ref. Pos. | Anz. Qty. Qte. Qta. Cant. Cant. Кол-во | Drehbühne mit KUD-Auflage / Slewing platform with slewing ring support / Ensembles mât cabine avec pivot cage / Piattaforma girevole con supporto della ralla di rotazione / Plataforma giratória com suporte de coroa dentada / Asiento pista con plataforma giratoria / Поворотная платформа с рамой ОПУ |  | 355 IC | 2,97 | 2,32 | 2,56 | 9290 |
| 1 | 1 | | | 500 HC | 3,05 | 2,32 | 2,57 | 11350 |
| 2 | 1 | Getriebebühne mit Einzieh- und Hubwerk** / Machinery platform with luffing and hoist gear** / Plate-forme des mécanismes avec méc. de relevage et de levage** / Piattaforma meccanismi con argano di sollevamento braccio e argano di sollevamento** / Plataforma de mecanismos con mecanismo de cambio de alcance y mecanismo de elevación** / Plataforma de mecanismos com mecanismos de basculamento da lança e de elevação** / Лебедочная платформа со стрелоподъемным механизмом и грузовой лебедкой** |  | | 6,74 | 2,45 | 2,94 | 15850 |
| 3 | 1 | Getriebebühne mit Einziehwerk, ohne Hubwerk / Machinery platform with luffing gear, without hoist gear / Plate-forme des mécanismes avec méc. de relevage, sans méc. de levage / Piattaforma meccanismi con argano di sollevamento braccio, senza argano di sollevamento / Plataforma de mecanismos con mecanismo de cambio de alcance, sin mecanismo de elevación / Plataforma de mecanismos com mecanismo de basculamento da lança, sem mecanismo de elevação / Лебедочная платформа со стрелоподъемным механизмом, без грузовой лебедки |  | | 6,74 | 2,18 | 2,48 | 11430 |
| 4 | 1 | Hubwerkseinheit** / Hoist gear unit** / Treuil de levage** Gruppo meccanismo sollevamento** / Mecanismo de elevación** 110 kW Grupo de mecanismo elevatório** / Блок грузовой лебедки** |  | | 2,98 | 2,46 | 1,30 | 4420 |
| 5 | 1 | Kabine mit Podest / Cabin with platform / Cabine avec plate-forme / Cabina con pedana / Cabina con plataforma / Cabina com plataforma / Кабина с площадкой |  | | 5,24 | 1,94 | 2,55 | 1850 |
| 6 | 1 | Seitenpodest rechts / Side platform / Plate-forme latérale Pedana laterale / Plataforma lateral / Plataforma lateral / Боковая платформа справа |  | | 2,15 | 1,17 | 0,77 | 100 |
| 7 | 1 | Seitenpodest links / Side platform / Plate-forme latérale Pedana laterale / Plataforma lateral / Plataforma lateral / Боковая платформа слева |  | | 3,77 | 0,90 | 0,82 | 180 |
| 8 | 1 | Seitenpodest rechts / Side platform / Plate-forme latérale Pedana laterale / Plataforma lateral / Plataforma lateral / Боковая платформа справа |  | | 5,41 | 1,10 | 0,82 | 270 |
| 9 | 1 | Auslegerhaltebock / Jib retaining frame / Chevalet de retenue de flèche / Cavallo tirante braccio / Caballete de soporte de pluma / Cavalete de suporte da lança / Кронштейн стрелы |  | | 11,95 | 2,20 | 2,34 | 5180 |
| 10 | 1 | Ausleger-Anlenkstück / Jib heel section / Pied de flèche Sezione articolata braccio / Pluma tramo primero Base articulada de lança / Корневая секция стрелы |  | | 11,23 | 1,87 | 2,04 | ① 1750 |
| 11 | 1 | Ausleger-Zwischenstück / Intermediate jib section / Élément intermédiaire de flèche / Sezione intermedia braccio / Tramo intermedio pluma / Peça suplementar da lança / Промежуточная секция стрелы |  | | 9,20 | 1,83 | 1,98 | ② 1360 |
| 12 | 1 | Ausleger-Zwischenstück / Intermediate jib section / Élément intermédiaire de flèche / Sezione intermedia braccio / Tramo intermedio pluma / Peça suplementar da lança / Промежуточная секция стрелы |  | | 10,55 | 1,83 | 1,98 | ③ 1500 |
| 13 | 1 | Ausleger-Zwischenstück / Intermediate jib section / Élément intermédiaire de flèche / Sezione intermedia braccio / Tramo intermedio pluma / Peça suplementar da lança / Промежуточная секция стрелы |  | | 5,18 | 1,83 | 1,98 | ④ 850 |
| 14 | 1 | Ausleger-Zwischenstück / Intermediate jib section / Élément intermédiaire de flèche / Sezione intermedia braccio / Tramo intermedio pluma / Peça suplementar da lança / Промежуточная секция стрелы |  | | 10,35 | 1,83 | 1,98 | ⑤ 1330 |
| 15 | 1 | Ausleger-Zwischenstück / Intermediate jib section / Élément intermédiaire de flèche / Sezione intermedia braccio / Tramo intermedio pluma / Peça suplementar da lança / Промежуточная секция стрелы |  | | 10,35 | 1,83 | 2,32 | ⑥ 1430 |
| 16 | 1 | Ausleger-Kopfstück / Jib head section / Pointe de flèche Punta braccio / Tramo punta de pluma / Cabeça de lança Концевая секция стрелы |  | | 11,23 | 2,23 | 2,46 | ⑦ 2720 |
| 17 | 1 | Unterflasche / Bottom hook block / Moufle inférieure / Bozzello inferiore Polipasto inferior / Gincho inferior / Крюковая обойма |  | | 1,45 | 0,74 | 1,90 | 1460 |
| Ballast | | Ballast / Lest / Zavorra Lastre / Lastro / Балласт | | | | | | |
| 18 | 1 | Stahlballast / Steel ballast / Lest en acier / Contrappeso di acciaio Lastres metálicos / Lastro metálico / Металлический балласт |  | | 4,40 | 0,31 | 0,88 | 4870 |
| 19 | 1 | Stahlballast / Steel ballast / Lest en acier / Contrappeso di acciaio Lastres metálicos / Lastro metálico / Металлический балласт |  | | 4,40 | 0,27 | 0,88 | 2940 |
| Kleinteile | | Small parts / Accessoires / Accessori Accesorios / Acessórios / Мелкие детали | | | | | | |
| 20 | 1 | Seile, Kleinteile / Ropes, small parts / Câbles, accessoires Funi, accessori / Cables, accesorios / Cabos, acessórios / Канаты, мелкие детали | | | | | 4500 | |

* Einzelgewichte. / Single weights. / Poids individuels. / Singoli pesi. / Tramo punta de pluma / Pesos de peças componentes. / Индивидуальный вес.

** Hubwerk ohne Sekundärbremse / Hoist gear without secondary brake / Mécanisme de levage sans frein secondaire / Argano di sollevamento senza freno ausiliario / Mecanismo de elevación sin freno secundario / Mecanismo de elevação sem freio secundário / Грузовая лебедка без вторичного тормоза

Konstruktionsänderungen vorbehalten! / Subject to alterations! / Sous réserves de modifications! / Riservato il diritto di modifiche strutturali! / Sujeto a modificaciones! / Salvo modificação da construçao! / Права на внесение конструкторских изменений сохраняются!

Sämtliche Angaben erfolgen ohne Gewähr. / This information is supplied without liability. / Ces renseignements sont sans garantie. / Tutte le indicazioni fornite senza garanzia. / Declinamos toda responsabilidad derivada de la información proporcionada. / Declinamos qualquer responsabilidade quanto à informação fornecida. / Все данные указаны без обязательств.